

SMU Course #: EETS 7315

DATA COMMUNICATIONS

Week #7 -- Dr. Baker

Summary-Review: Transparency & Flexible Protocol Techniques

- Three techniques for achieving data transparency:
 - Constant data field length
 - Bit or character stuffing
 - Length field ahead of data
- Recall HDLC Option 7 for creating a variable-length field.
- Most of these techniques will be revisited.

Review: The Purpose of Layer 3

- We have seen how Data-Link Protocols govern the transmission of data between two TEs.
- Note that the TEs could just as well be network nodes.
- Layer 3 protocols can route and relay data through a network from Data-Link to Data-Link.

Definition of a Virtual Data Circuit

- A Virtual data circuit is a circuit that is created by the receiving and forwarding of bits by computers located at network nodes, such that it is possible to multiplex one end of many virtual circuits at the same network port.
- Virtual circuits can be connection- oriented or connectionless.

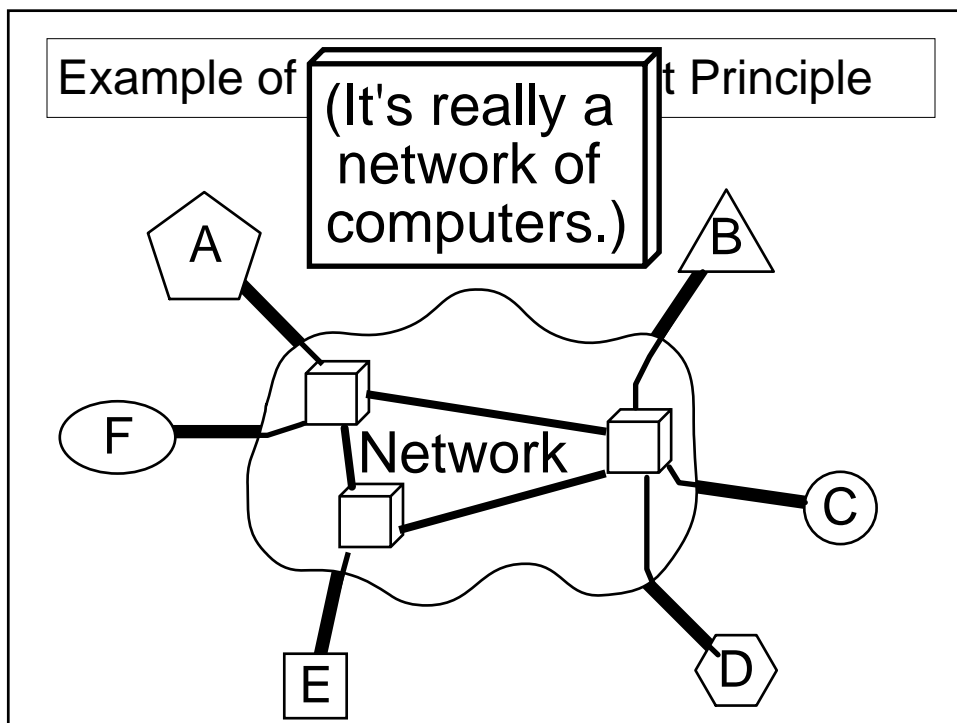
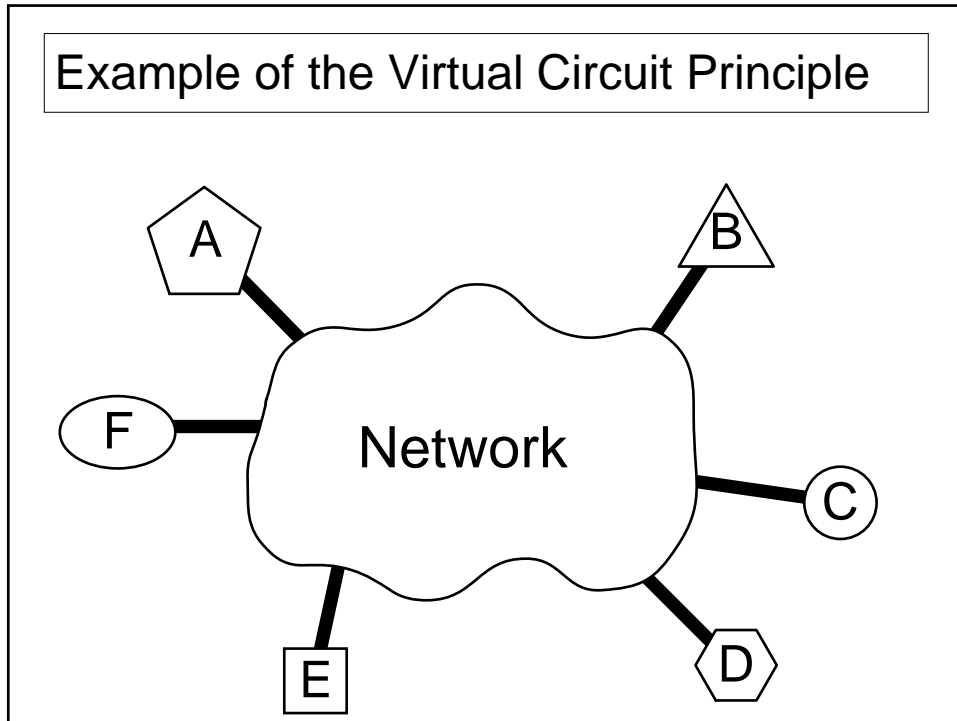

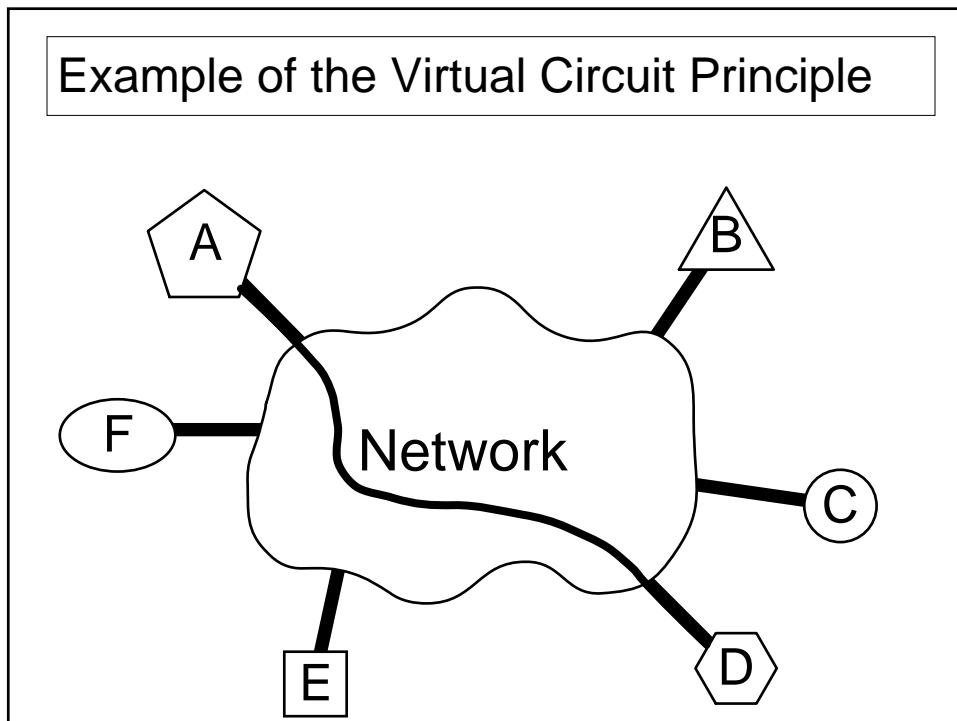
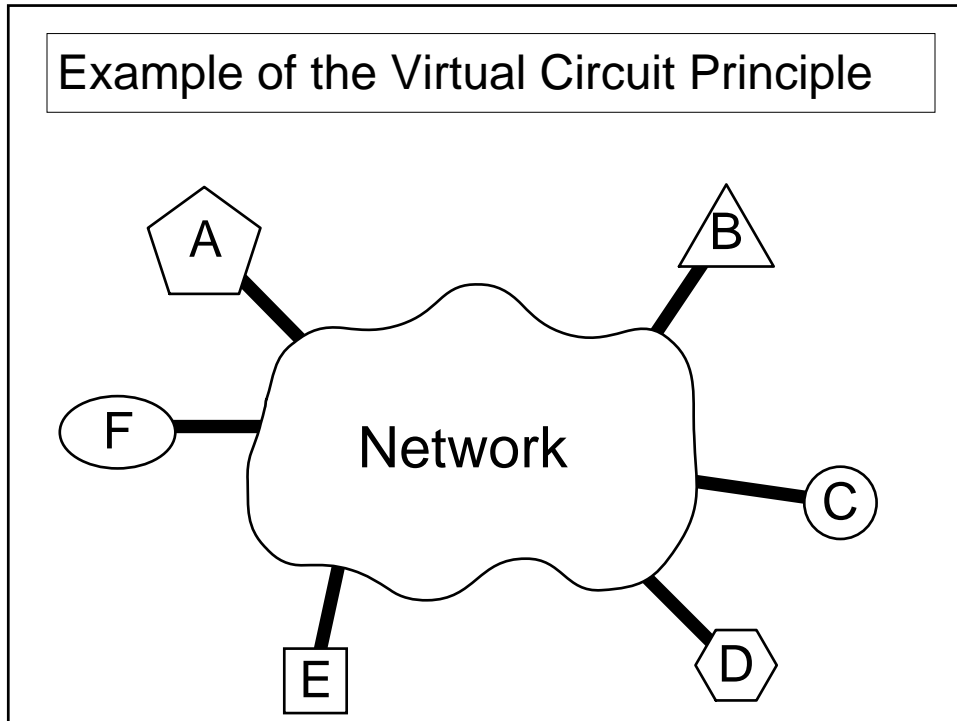

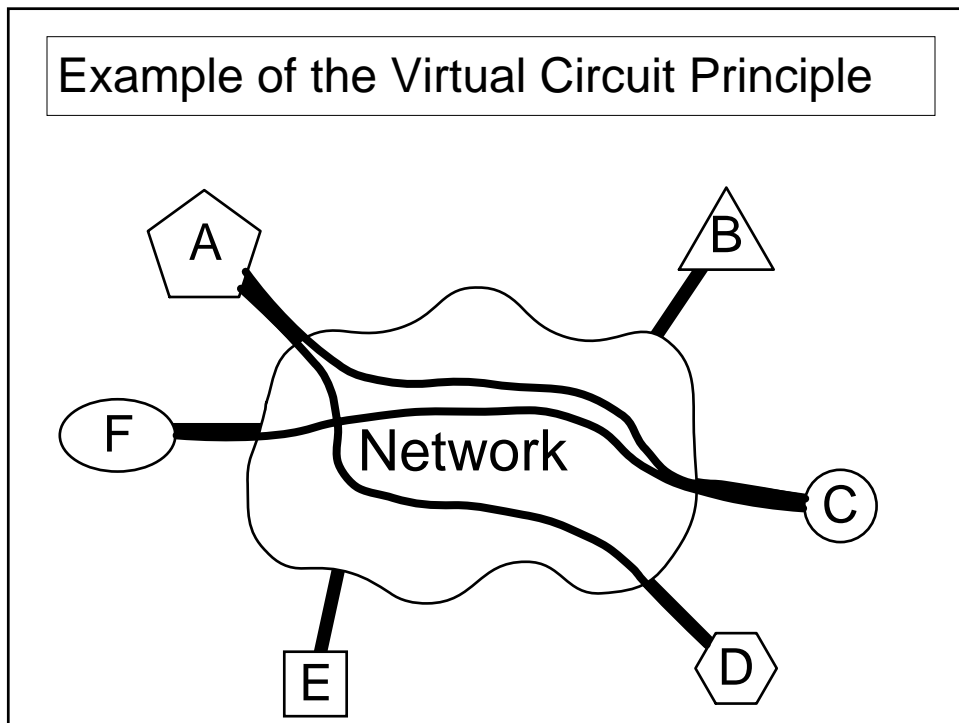
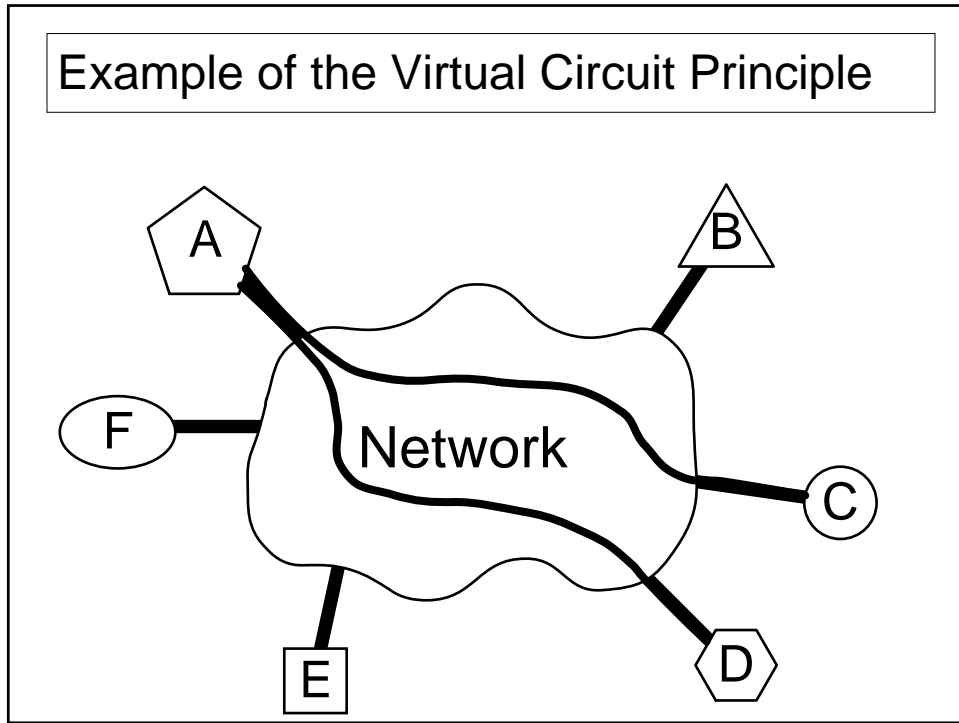

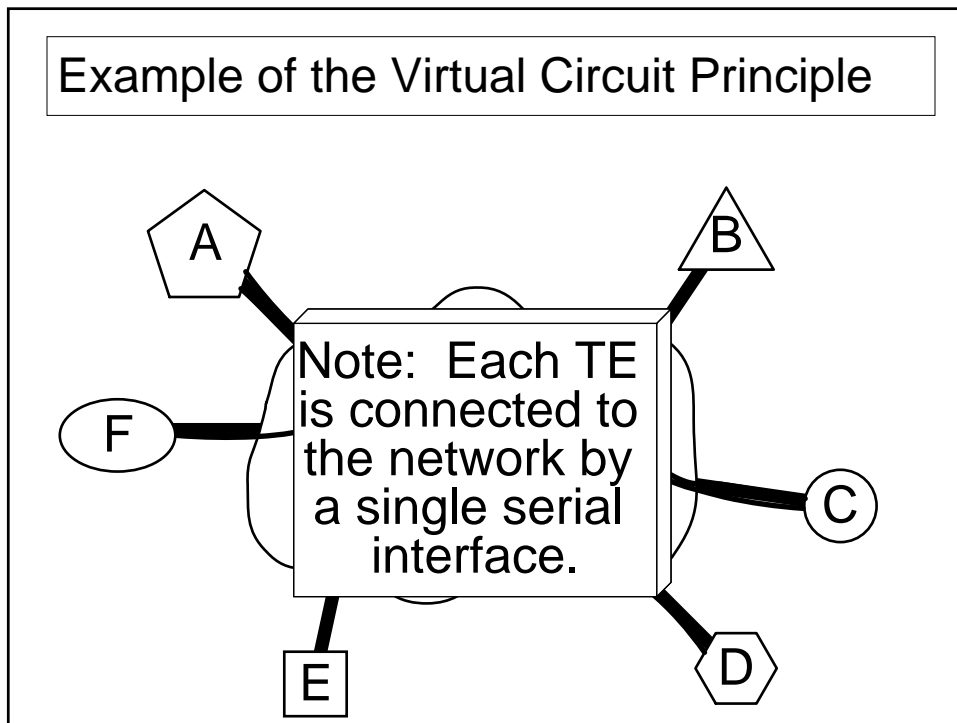
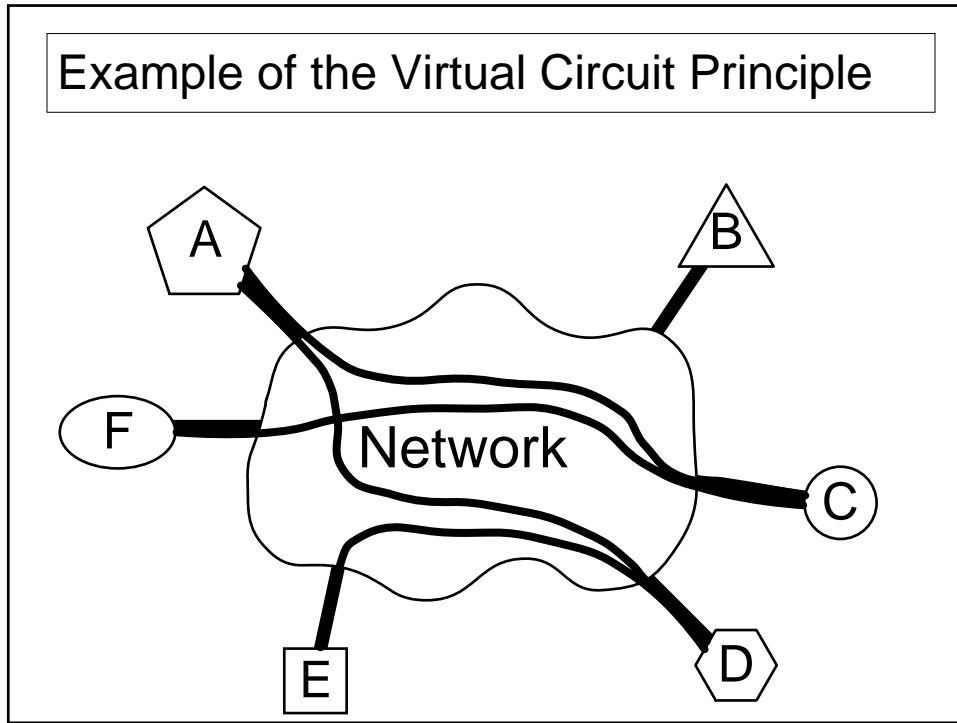

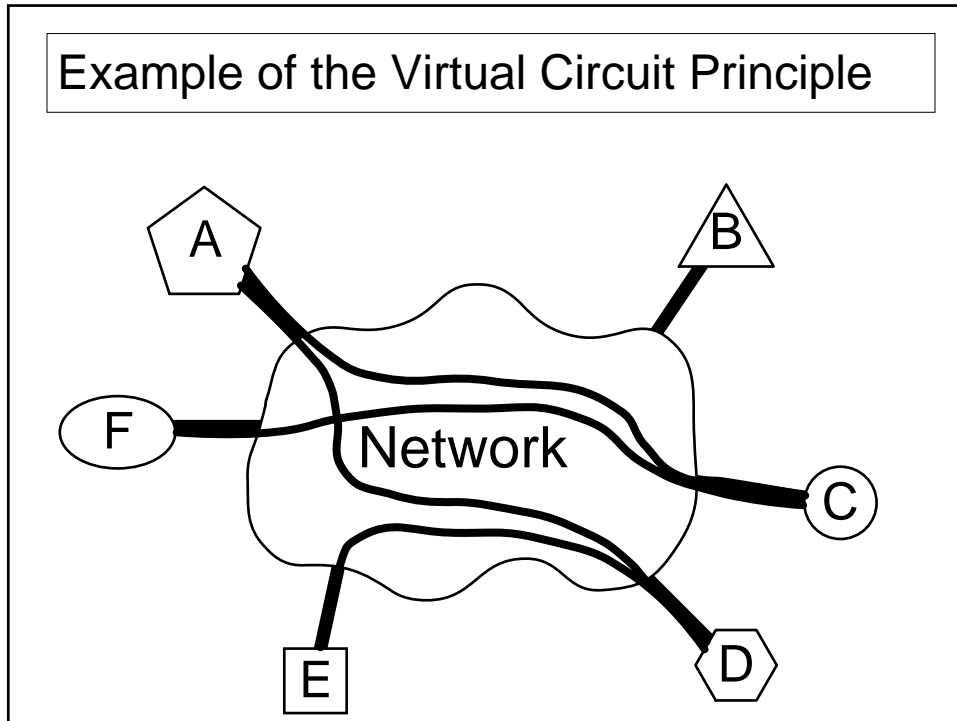

- Question: How many virtual circuits can you have in a serial interface?
- Answer: How many buffers can you build into a computer?

Introduction to X.25

- Packet switching networks are an important type of receive-and-forward virtual data network.
- X.25 is an interface standard that defines the relationship between a TE and a packet network.
- X.25 only exists in the access line between the TE and the packet switching network.

Important Note:

X.25 normally does not exist in the network trunks, only in the access lines!

Definition: X.25 Logical Channel

An X.25 Logical Channel
is that portion of an X.25
Virtual Circuit
which exists in the
access line.

Distinction: Layer 3 has sublayers

- An end-to-end network is often made up of subnetworks.
- The lower part of Layer 3 can be subnetworks. (Example: a packet subnetwork of a larger network)
- The upper part is called the Internet Sublayer (a.k.a. Layer 3.5). It ties the subnets together into a catanet.

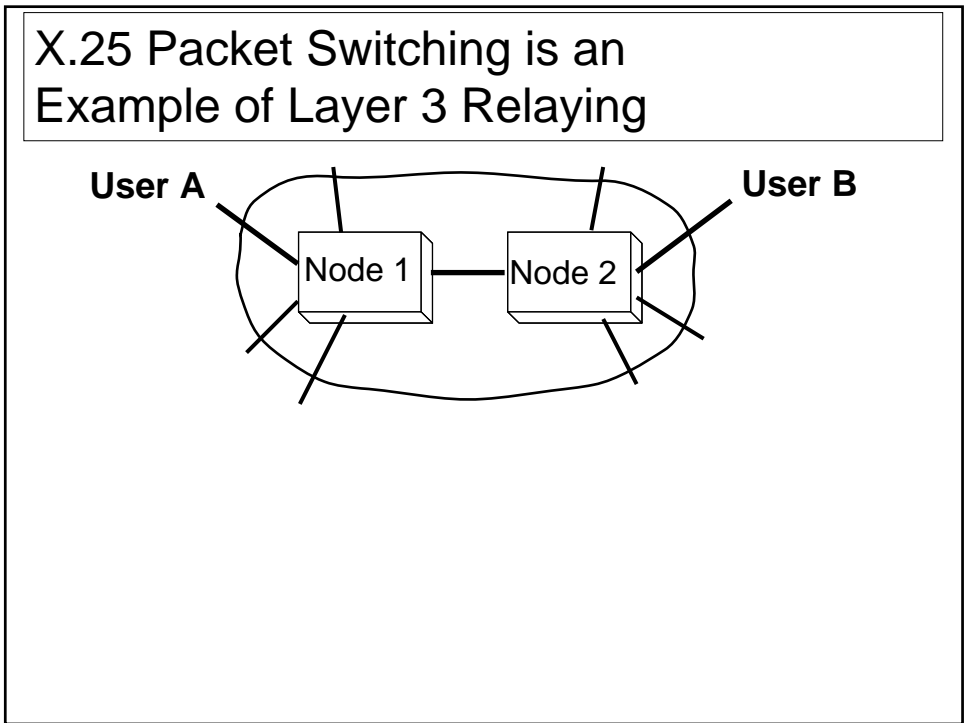
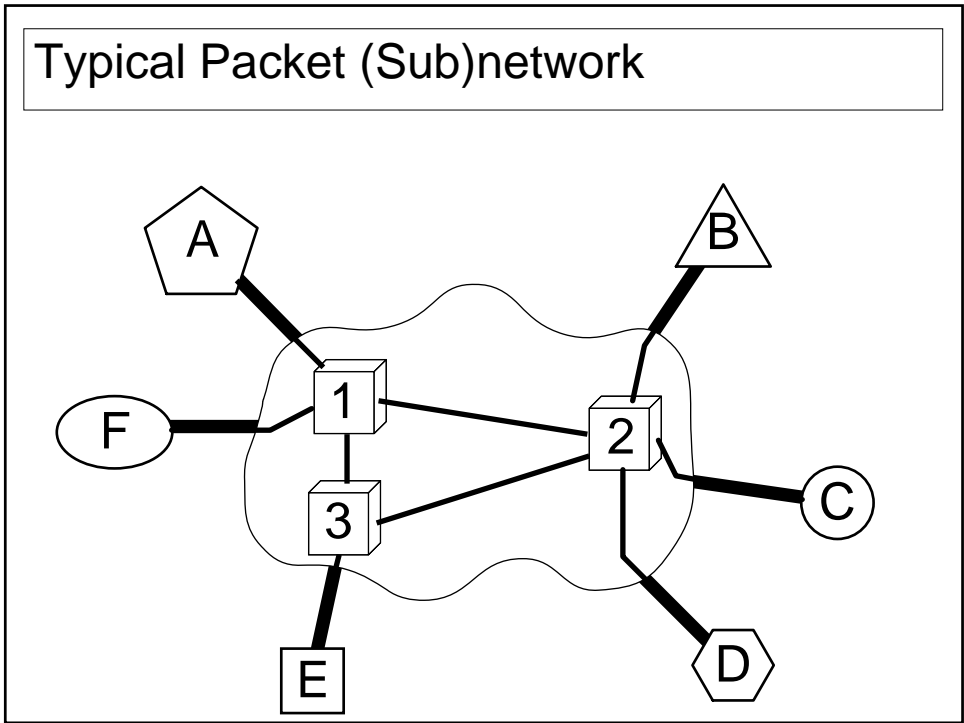

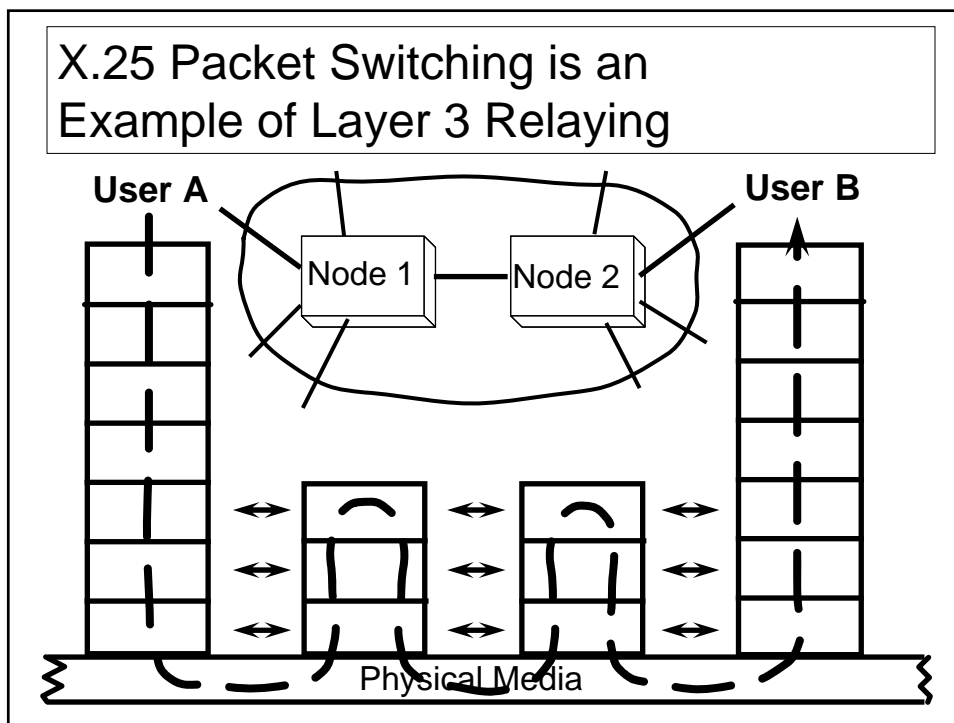
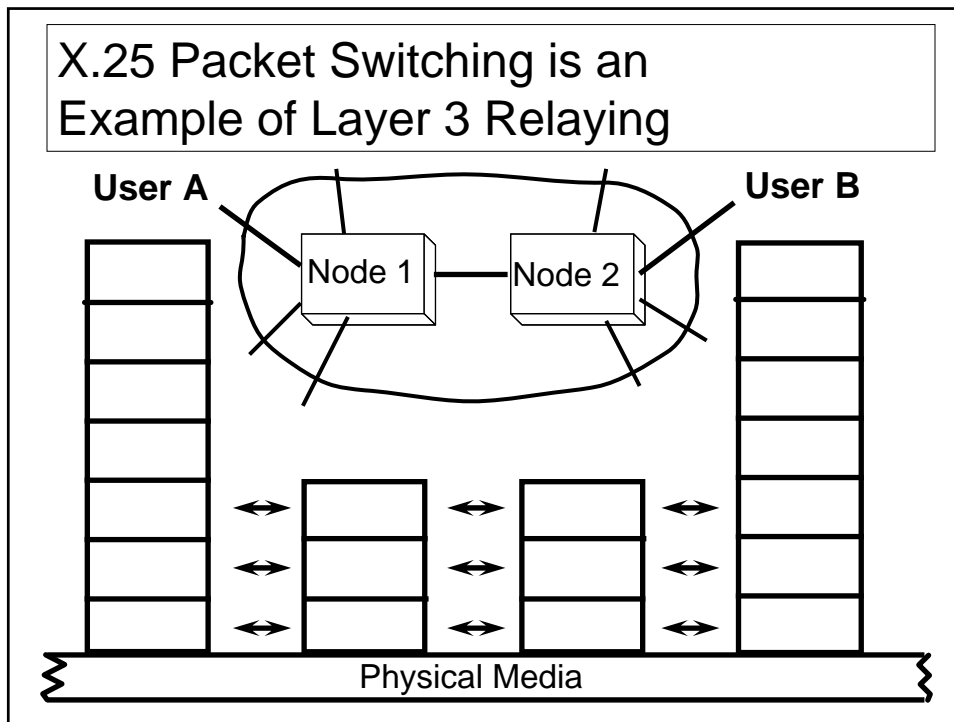

LAPB (Layer 2 of X.25)

- Link Access Procedure (Balanced) is the name of the data-link protocol used in X.25
- LAPB consists of the following:
HDLC BA Class
Options 2, 8, and (rarely) 10
- For the A field:
TE = 00000011
Node = 00000001

Observations

- Since we are using HDLC Option 8, there can be no I-frame in a response
- Since X.25 packets can only reside in I-frames, there can be no packet in a response
- All I-frames contain packets, and all packets are in I frames

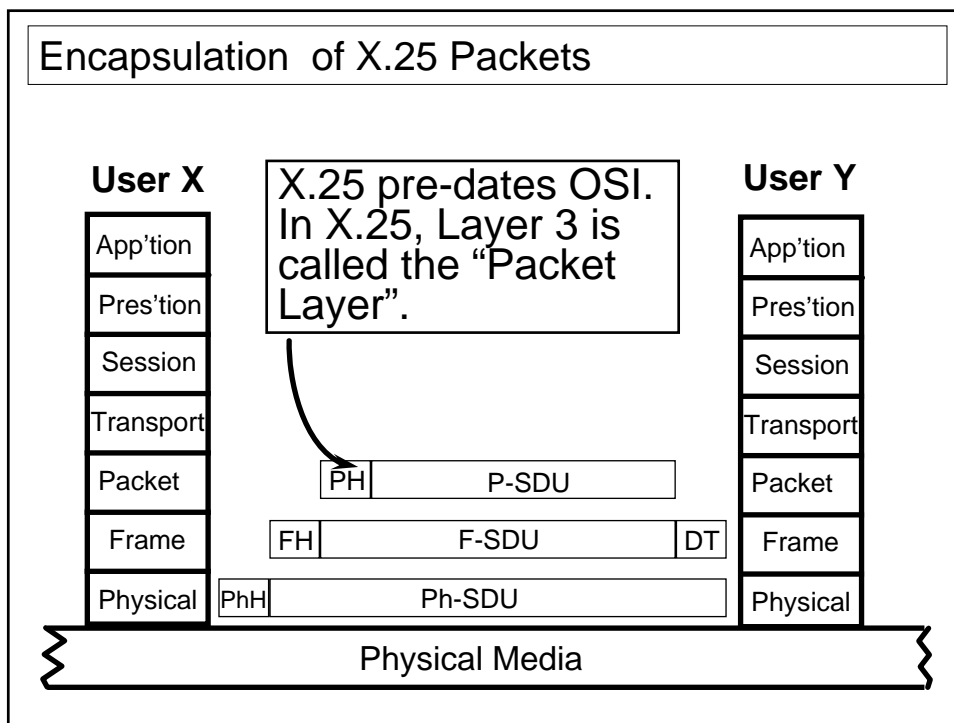
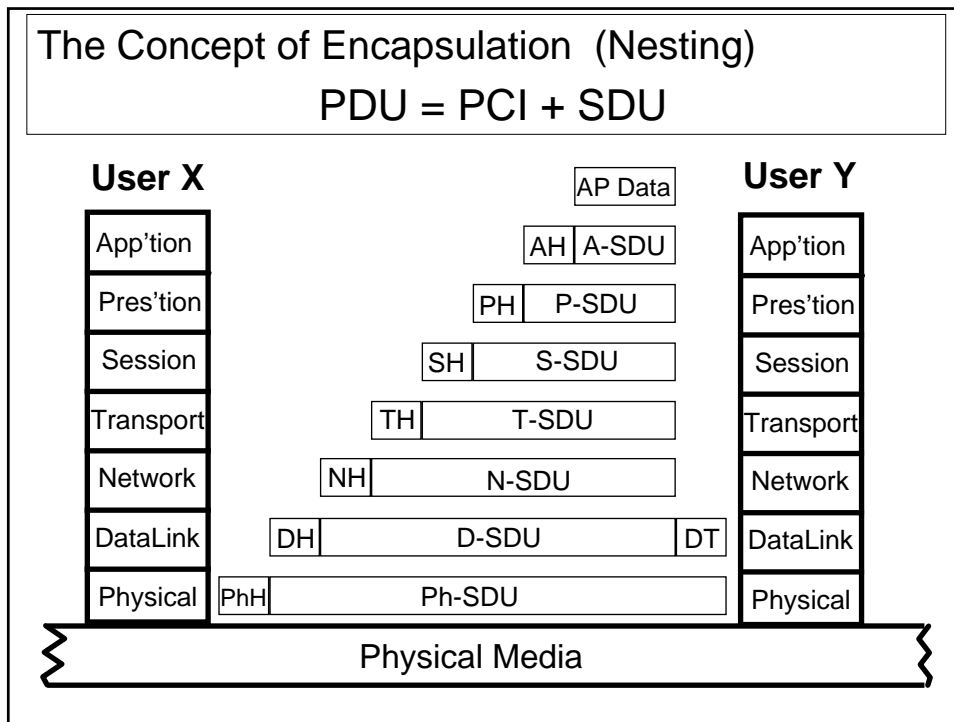

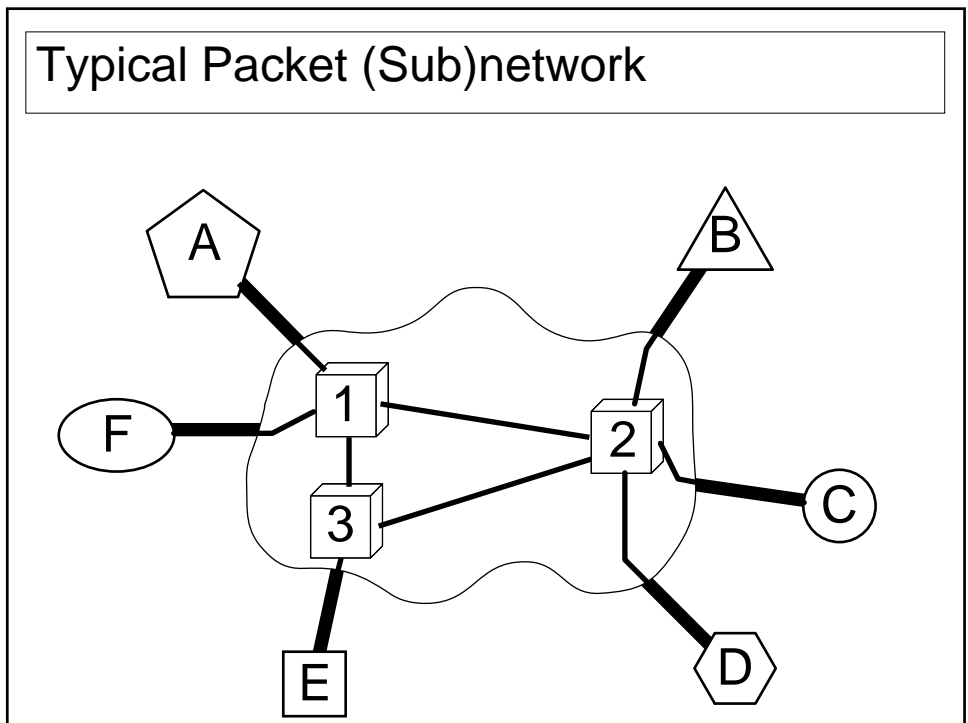
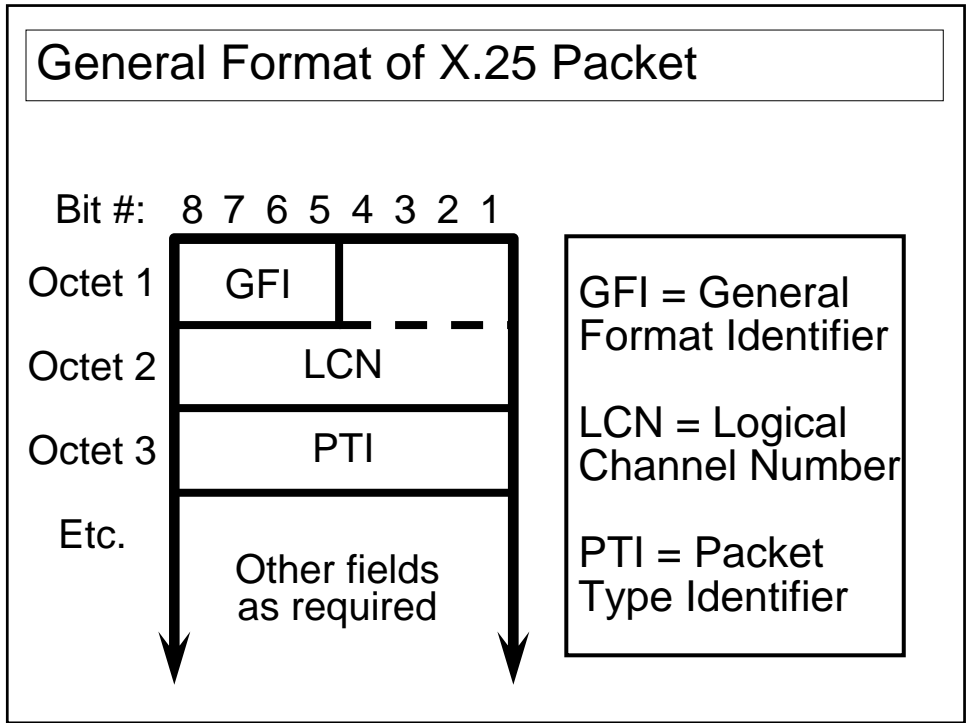

X.25 Packet Types

- Data Packets
- Interrupt Packets
- Flow Control
- Reset
- Restart
- VC Setup & Clearing

X.25 Services

- Review: In the language of the telecommunications industry, a Service is a tariffed product.
- X.25 specifies two types of Services:
PVC (Permanent Virtual Circuit)
and
VC (Virtual Call)
- VC is sometimes called SVC (Switched Virtual Connection)

Definitions

- Review: All X.25 virtual circuits, protocols, and services are connection-oriented.
- A PVC is created by the network provider at the request of the customer. Routing tables and other capabilities are established by subscription.
- A VC is created and cleared dynamically by the customer using set-up and clearing sequences.

Virtual Call Set-up and Clearing

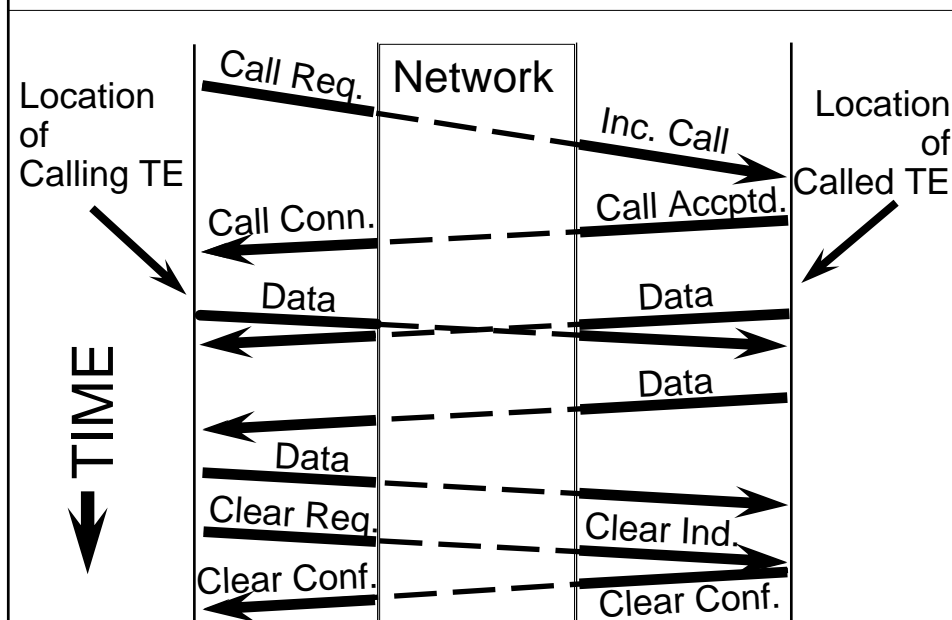

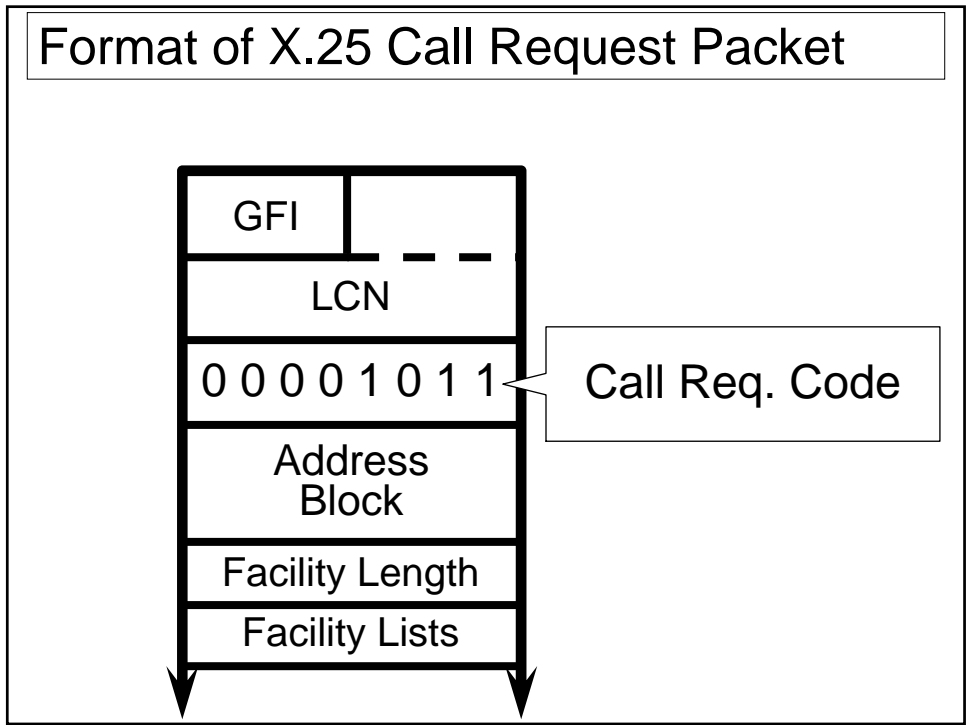
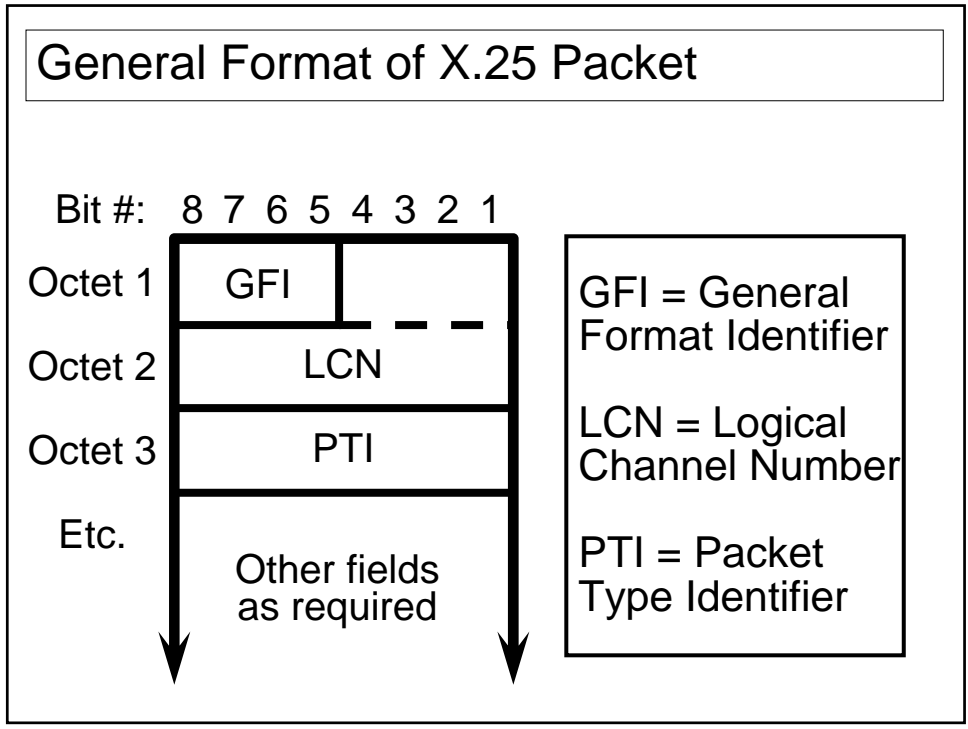

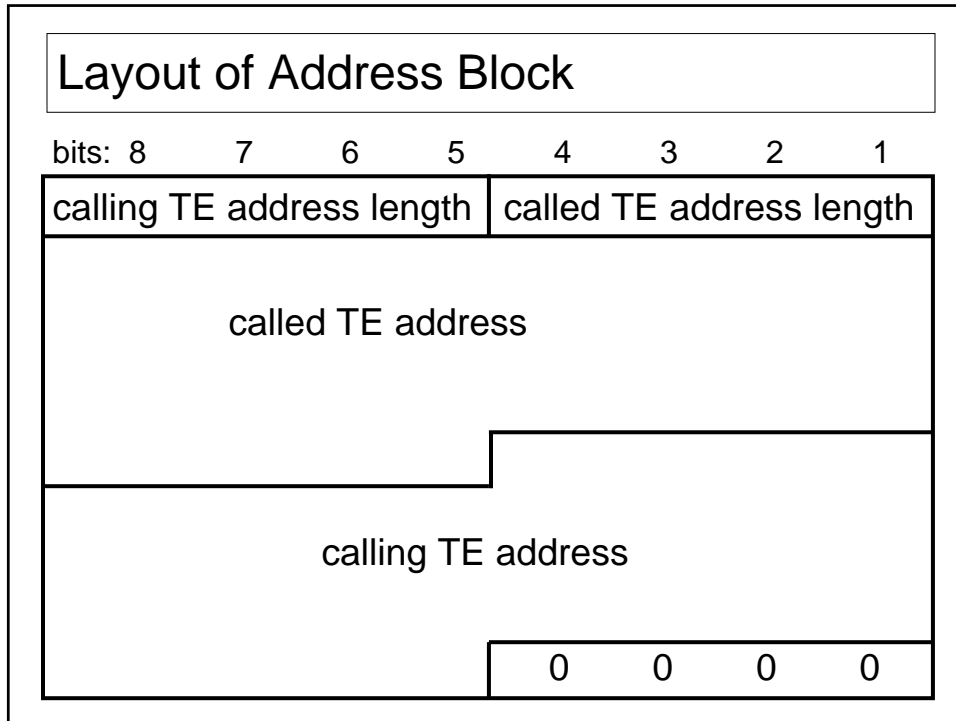

Definition: Facilities

- The language of the CCITT, when translated into English comes out "British."
- "Facilities" means "Options."

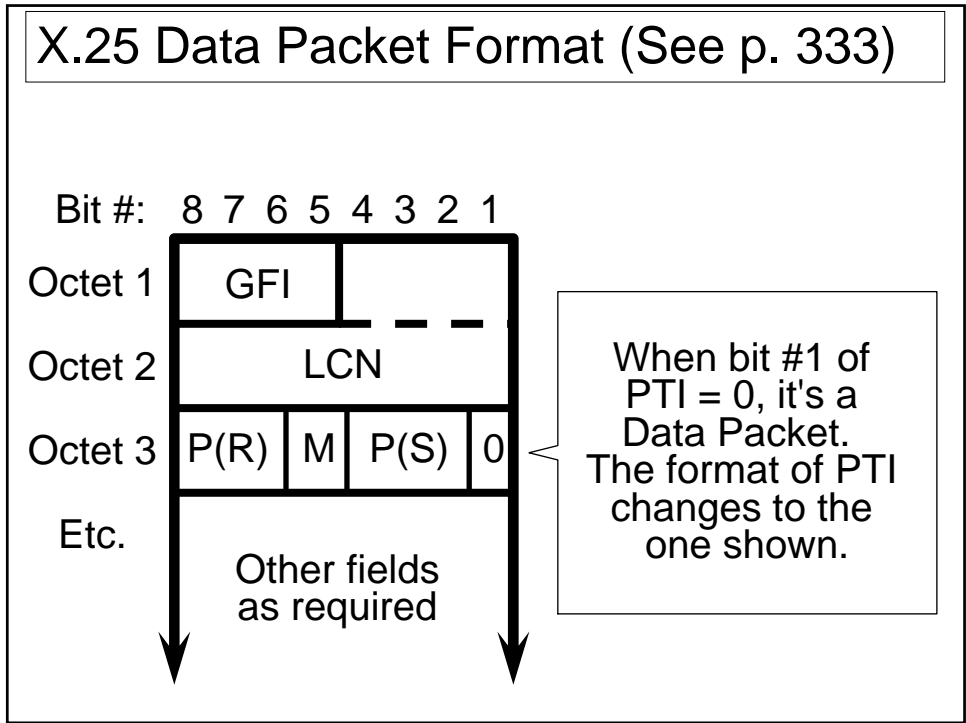

D-bit Confirmation (Bit #7 of GFI)

- When D = 0, a data packet is acknowledged from the first packet node at the next opportunity for a P(R) to be sent.
- When D = 1, the first packet node withholds acknowledgements until it receives notification that the receiving TE has acknowledged receiving the packet.

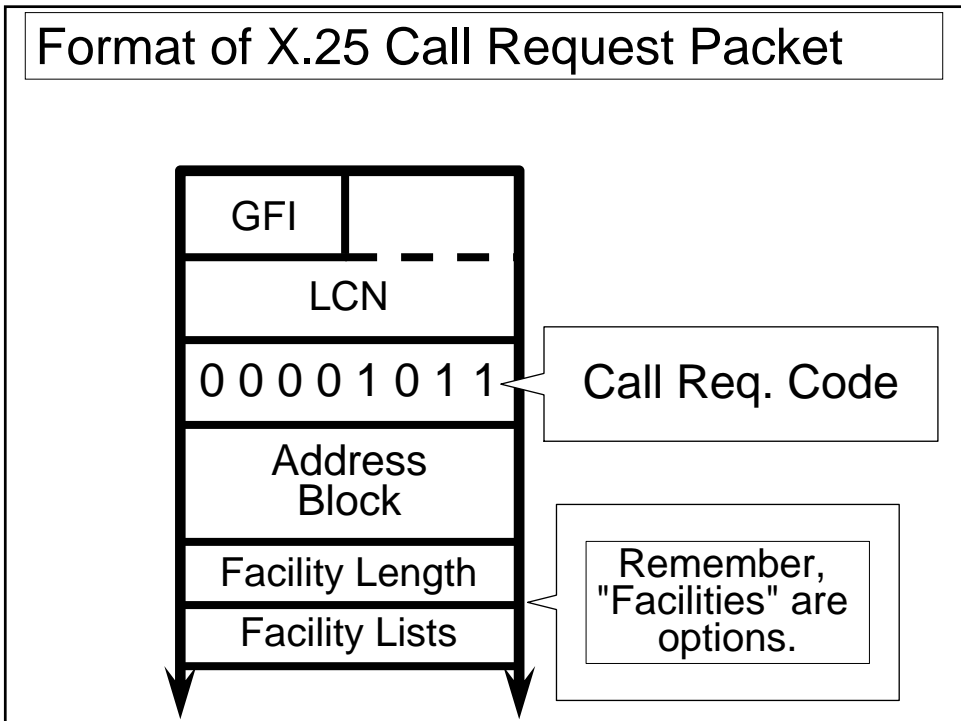
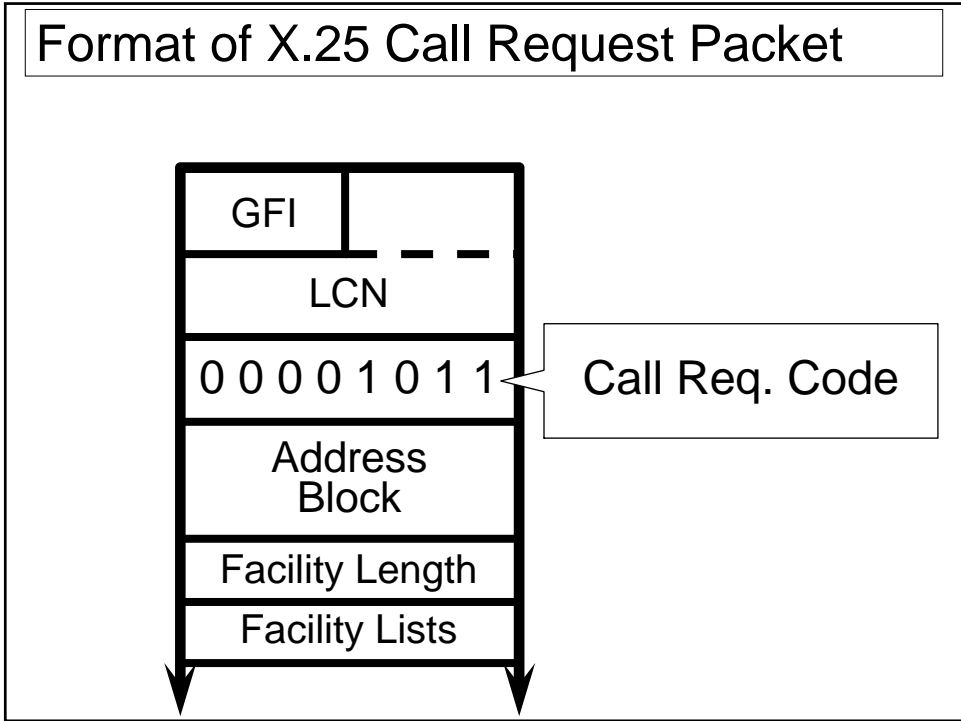

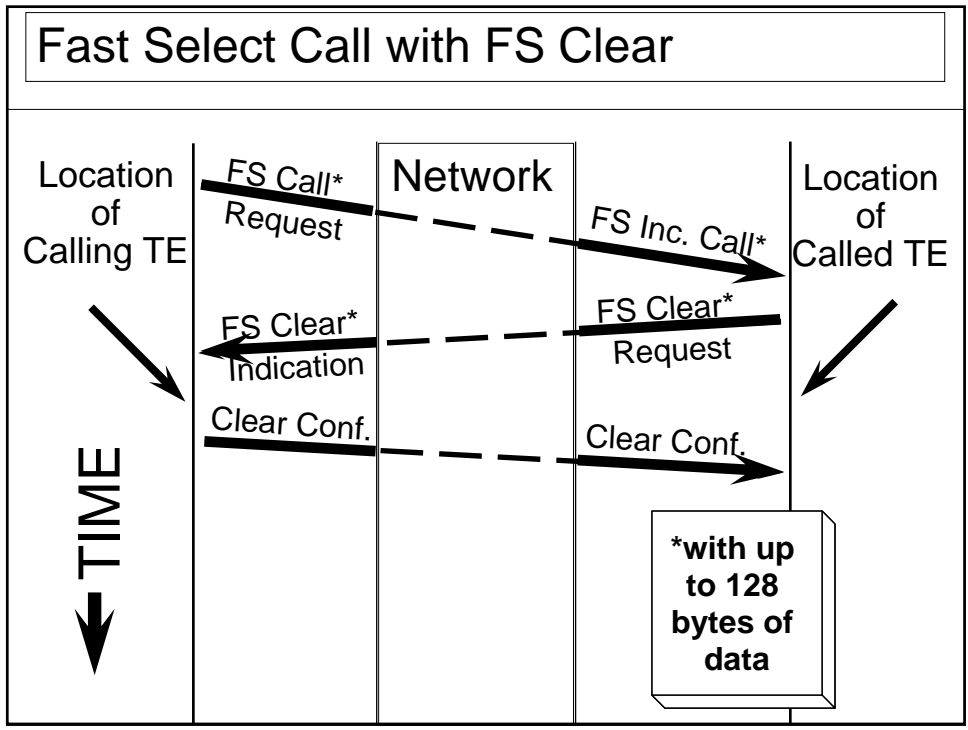
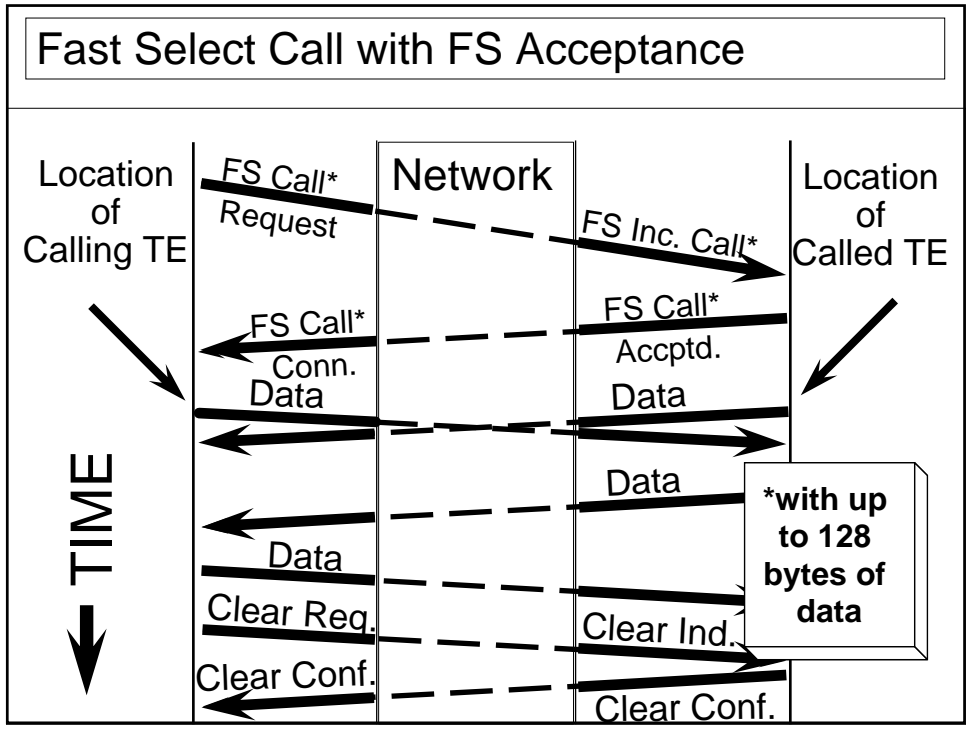

Examples of Facilities

- Fast Select
- Reverse Charging
- Closed User Group
- Change of Modulus
- Change of Window
- Change of Maximum Packet Size
- Etc.

Connection-Oriented Internetworking

- Note the two approaches
- The classical approach to connecting two connection-oriented networks is by "splicing"
- X.75 splicers are called STE's (Signaling Terminals)
- An STE circuit board (a.k.a. X.75 module) plugs into a node at each end of an internet trunk

Relationship of Standards

- X.25 -- a 3-layered architecture describing layers 1-3 in DTE/DCE interface
- X.75 -- 3-layered architecture describing layers 1-3 in STE/STE interface between 2 public networks
- X.96 -- Specification of "Call Progress Signals." These are codes that X.25 needs in order for a DTE to know what is going on across the network.

Gluing it all together

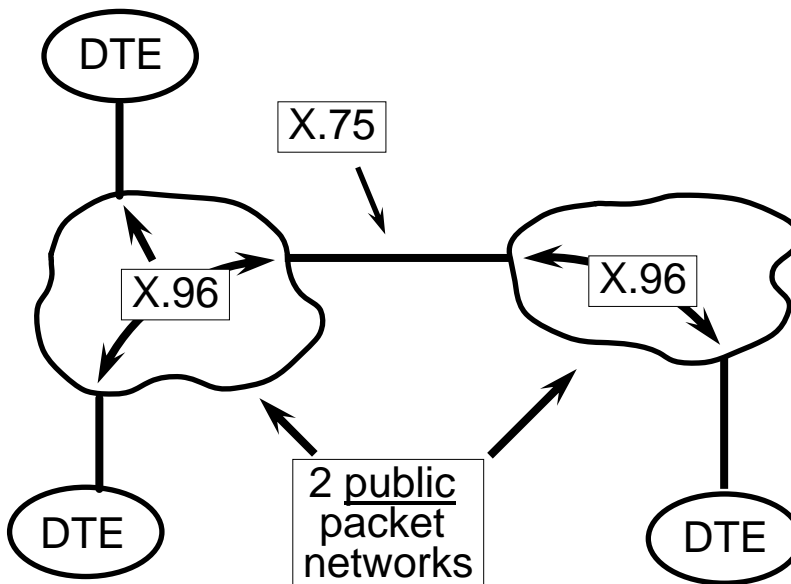

Characteristics of X.75

Almost the same as X.25, except

- X.25 is non-symmetrical; X.75 is symmetrical
- X.75 has an extra block of Network Utility fields in the call set-up packets
- The Network Utility fields mainly give info about the other network

Examples of X.75 Utilities

- Transit network I.D.
- Window size
- Packet size
- Reverse charging indication
- Tariff code
- RPOA selection
- Type of addressing scheme
- Throughput class

Examples of X.96 Codes

- Network congestion
- Network out of order
- Changed number
- Access barred
- Reverse charge acceptance not subscribed
- Fast select acceptance not subscribed
- Number busy
- Ship absent

Gluing it all together

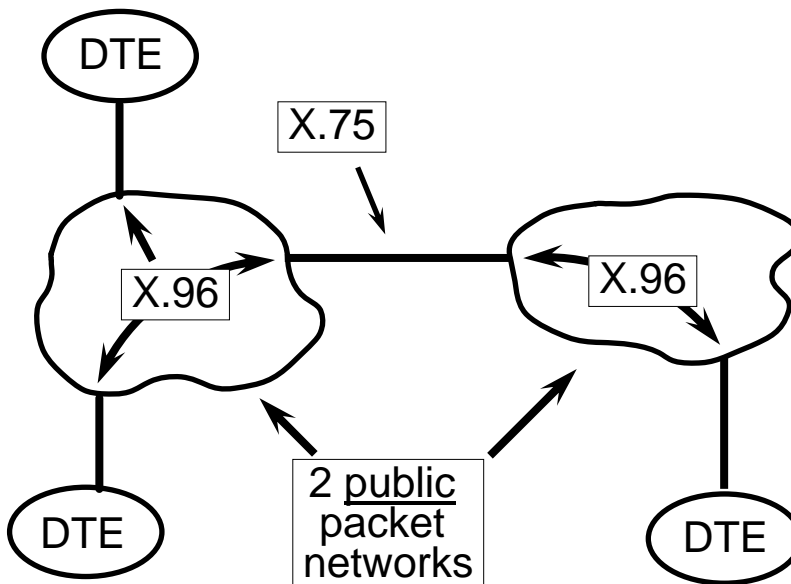

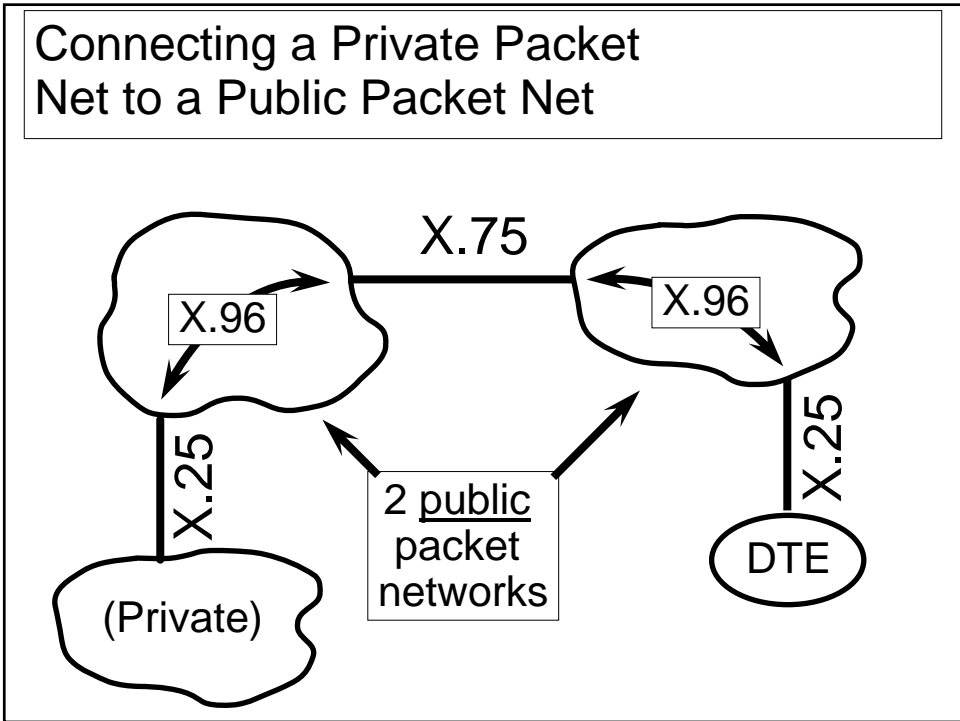
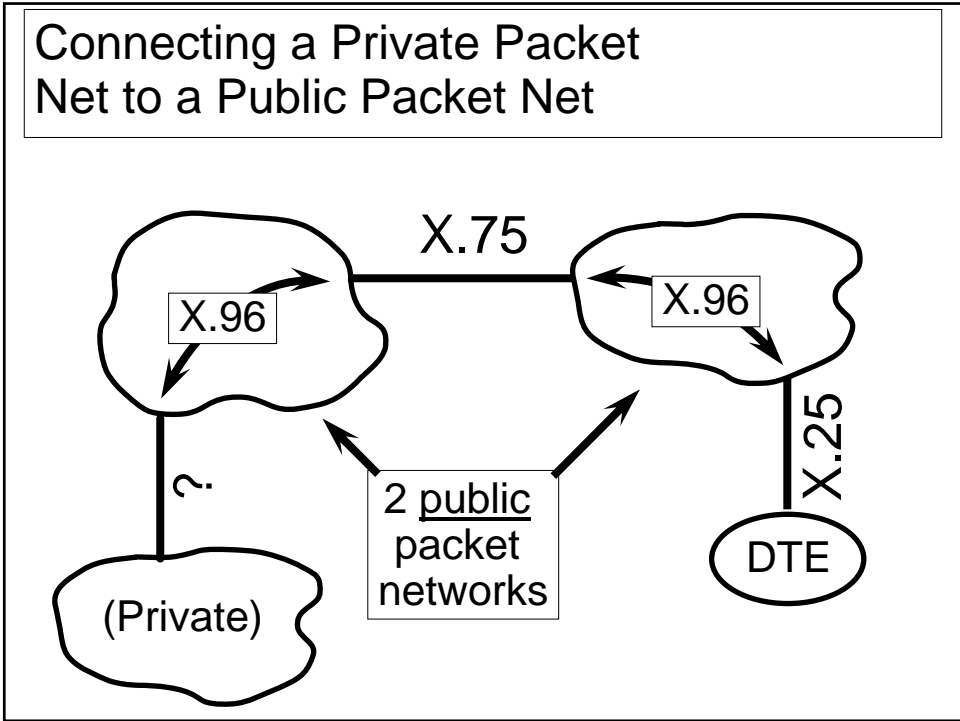

Concentrators versus Multiplexers (See Handouts.)

- Multiplexers physically combine multiple channels at some point into a higher capacity circuit, and physically decombine (split-out) elsewhere
- Concentrators also physically combine multiple channels, but there is no physical splitting elsewhere. The splitting is usually handled by software