

**SMU Course #: EETS 8301**

**DATA COMMUNICATIONS**

Week #11 -- Dr. Baker

Token Ring uses a Logical Bus  
in the shape of a Physical Ring

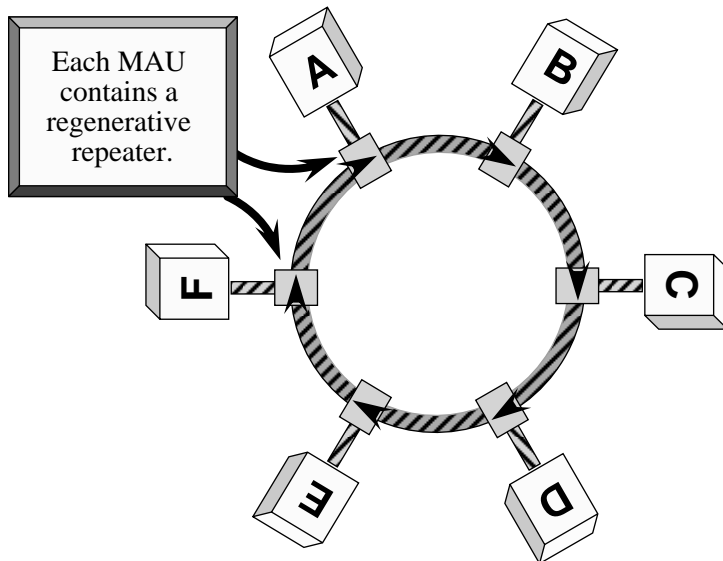

### How Token Ring Works (IEEE 802.5)

1. All bits, including token bit, make one complete revolution, in same direction, around ring. Since every bit is seen by every MAC, it's a bus.
2. Each terminal's MAC (Medium Access Controller) is in either a bit-passing or a transmission mode.
3. When a terminal wishing to transmit sees a token, it seizes and may then transmit.
4. A transmitting terminal kills its own frame.

### Token Ring Concerns

- The order of token passing is not variable.
- In a lightly loaded system, the token-passing wastes time.
- A link break or repeater failure can kill the whole network.
- Centralized controllers simplify troubleshooting but increase cable cost.

Token Ring uses a Logical Bus  
in the shape of a Physical Ring

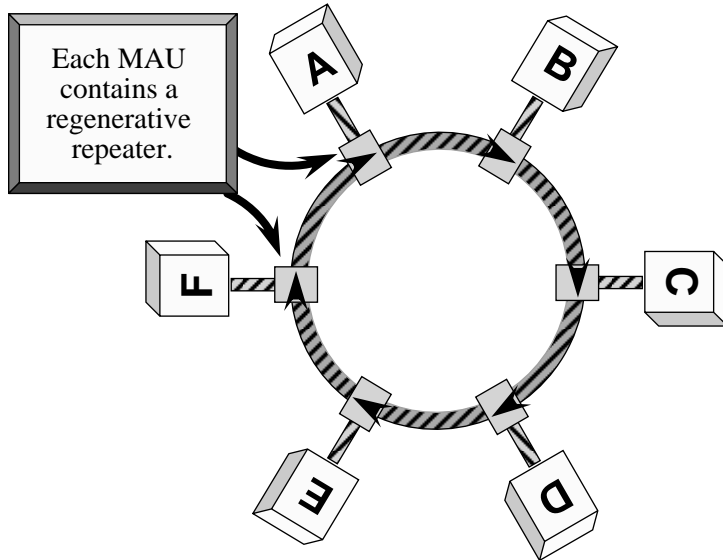

Typical Token Ring using  
a Central Controller

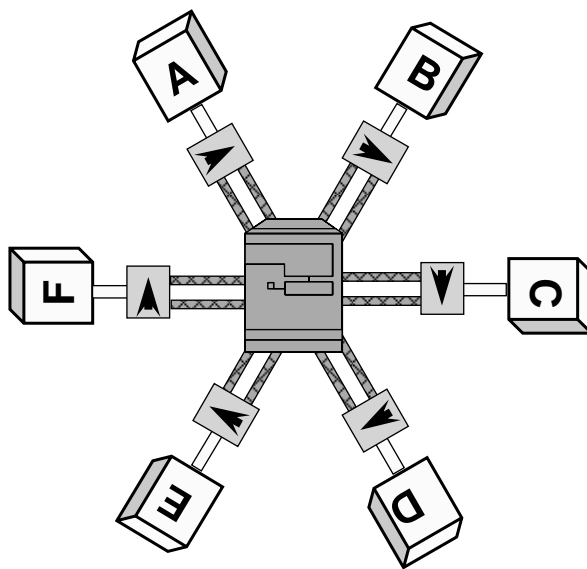

### Fiber Distributed Data Interface\*

- A 100 Mb/s system similar to Token Ring.
- Slight differences in MAC protocol improve throughput and transit delay.
- Present implementations are expensive.
- A double ring can be used to provide redundancy in the event of cable failure.
- Bridges are available to allow double ring where needed and single elsewhere.

\*FDDI

### DQDB (The IEEE 802.6 Standard)

- Title: Distributed Queue Dual Bus (DQDB) Subnetwork of a Metropolitan Area Network (MAN)
- It can be used to tie together various LANs in a building or campus, or as a LAN, MAN or WAN, at least to OC3 rates (155 Mb/s)
- For the same medium, it has at least the throughput of FDDI, with the same average transit delay as FDDI. Unlike FDDI, it can be used as a WAN backbone

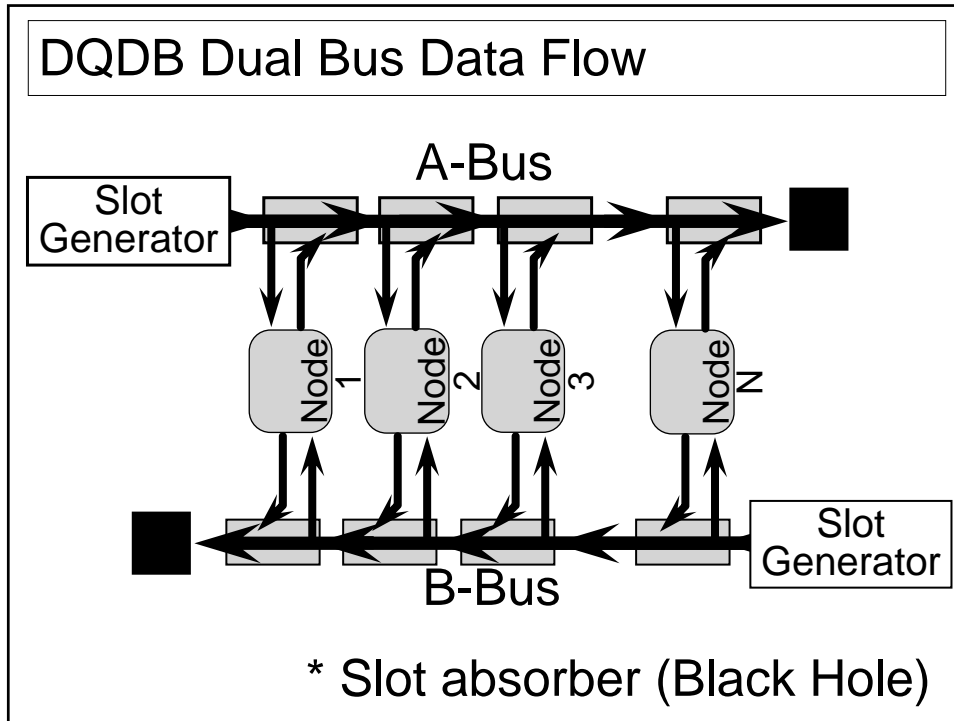

### The "Dual Bus" – How it Works

- Each bus carries time slots ("bit buckets") in one direction
- Each node (terminal or network port) can receive bits from, and can put bits into, slots on each bus
- Each node "knows" on which bus to send a slot to get it to any other node
- The first octet in each slot contains a "Busy" bit and a "Request" bit

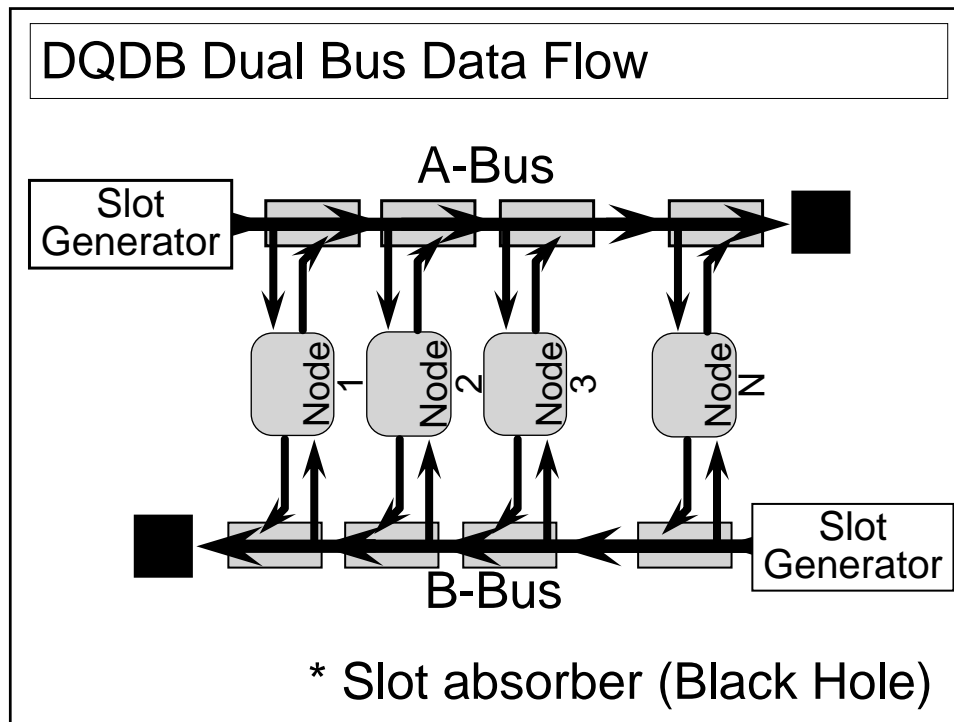

### The "Distributed Queue" Access Protocol

- The Busy bit tells the status of that slot.
- The Request bit is sent "upstream" by a node wanting to send data.
- Each node, by counting the number of requests it sees and the number of unused slots that pass, can determine the number of nodes queued ahead of it.
- When its turn comes, the node transmits.
- A redundant wrap-around version is available.

### Common Factors Affecting LANs and MANs

- The chief MAC issue: when to transmit.
- The data flow tends to be very bursty.
- All popular schemes use a logical bus concept.
- Only one up to a very few messages can flow at the same time.
- Average information throughput tends to be much lower than peak bit rate.

### Common Factors Affecting LANs and MANs (2)

- Since the issue is "when to transmit," it is common in LANs and MANs not to require acknowledgment (ack) at Layer 2.
- To require an ack for each frame would mean that the ack would be in as much jeopardy of collision, or would have to wait its turn, just as the data frame.
- Therefore, such systems almost universally use Type 1 (connectionless) control field of the LLC sublayer.

## Clarification on Repeaters (sometimes called "bridges")

- Repeaters don't check addresses or formats or detect errors. They operate in Layer 1.
- A Repeater is used to extend the length of a medium by detecting bits, and re-timing, re-shaping, amplifying and re-transmitting those bits into a new medium.
- Multiport repeaters can also be used to simulate a multipoint medium using point-to-point media. (Example: Fiber)

## Examples of Repeaters

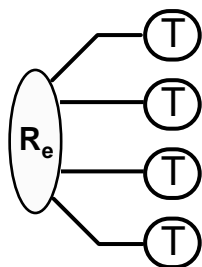

*Note: Repeaters link sub-networks that contain the same protocols and topology.*

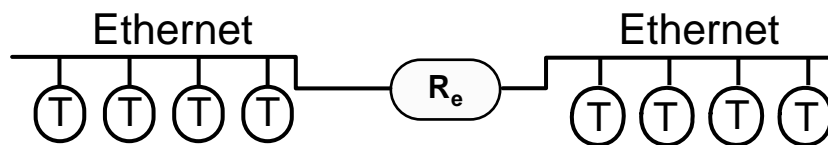

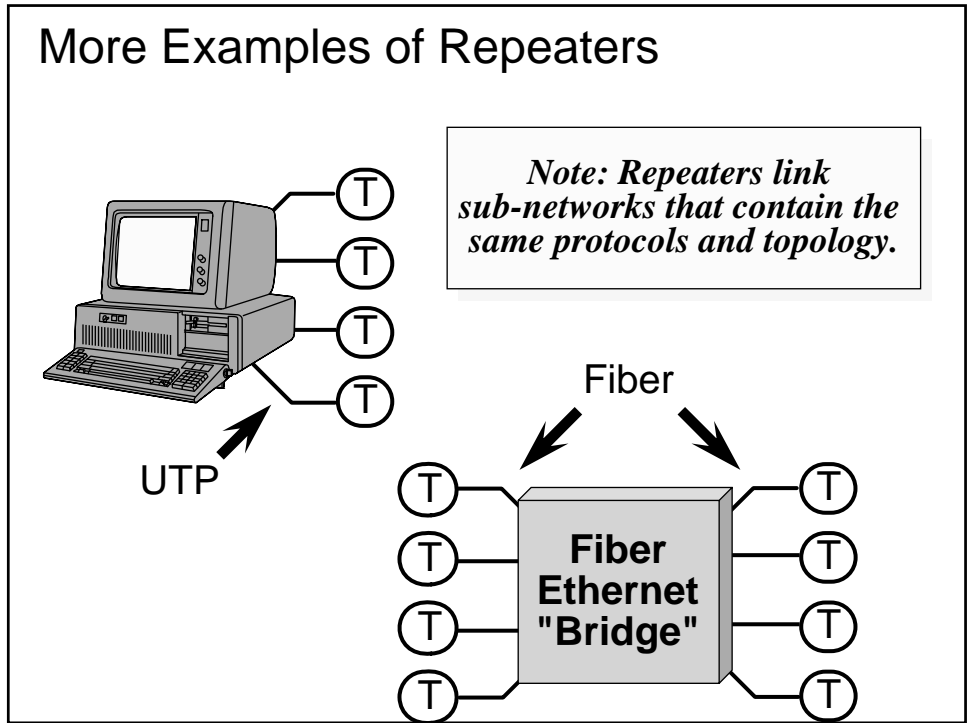

### The LAN Switch

- LAN Switch looks just like a multiport repeater except that it is a Layer 2 device:
- The hub reads the MAC DA and sends the frame only to the specific line for that terminal.
- There are separate send and receive UTPs in each cable.
- There are no collisions if the switch has sufficient paths and if each terminal has a dedicated switch port

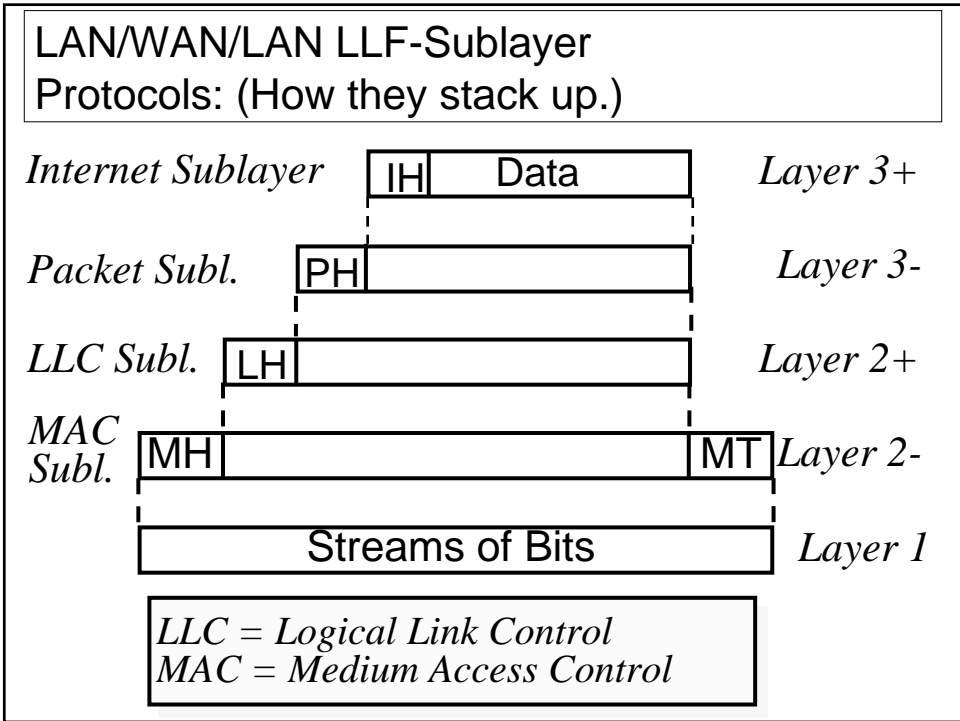
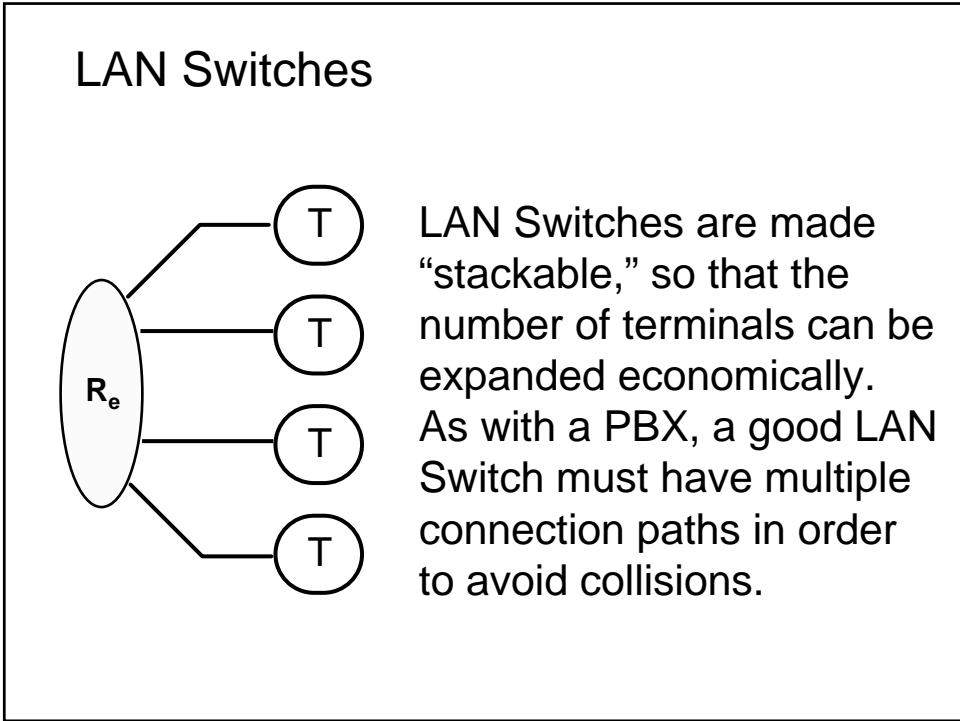

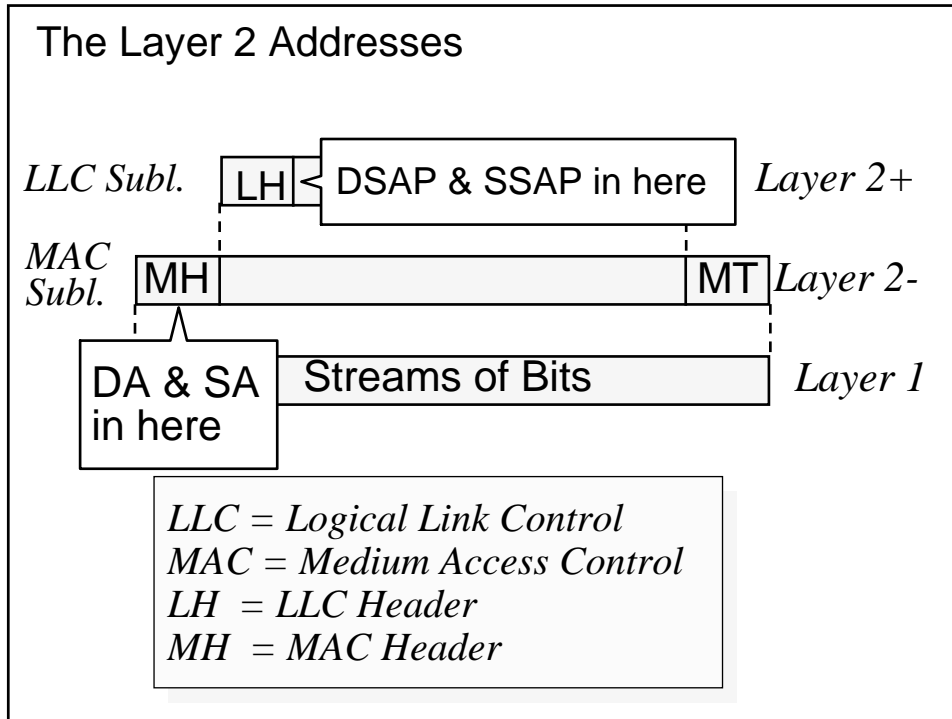

### Interpretation of Layer 2 Addresses

- The DA and SA in the MAC header are the respective destination and source addresses describing the end nodes of the LLC PDU's travel in Layer 2.
- The DSAP and SSAP specify respective software or other functions relating to the treatment of the LLC PDU at the DA and SA points.

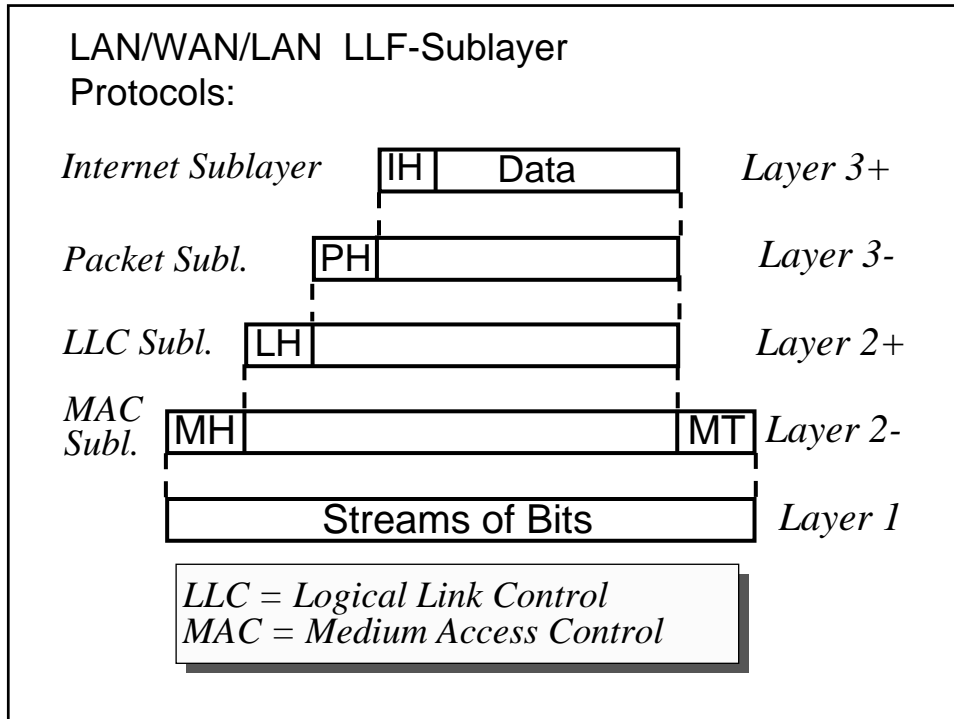

## Routers

- A concatenation of subnetworks is sometimes called a catanet.
- The device that creates catanets from subnetworks is called a router.
- Routers use Internet Sublayer protocols to relay internet information across the catanet.
- Routers give maximum flexibility to network evolution and routing.

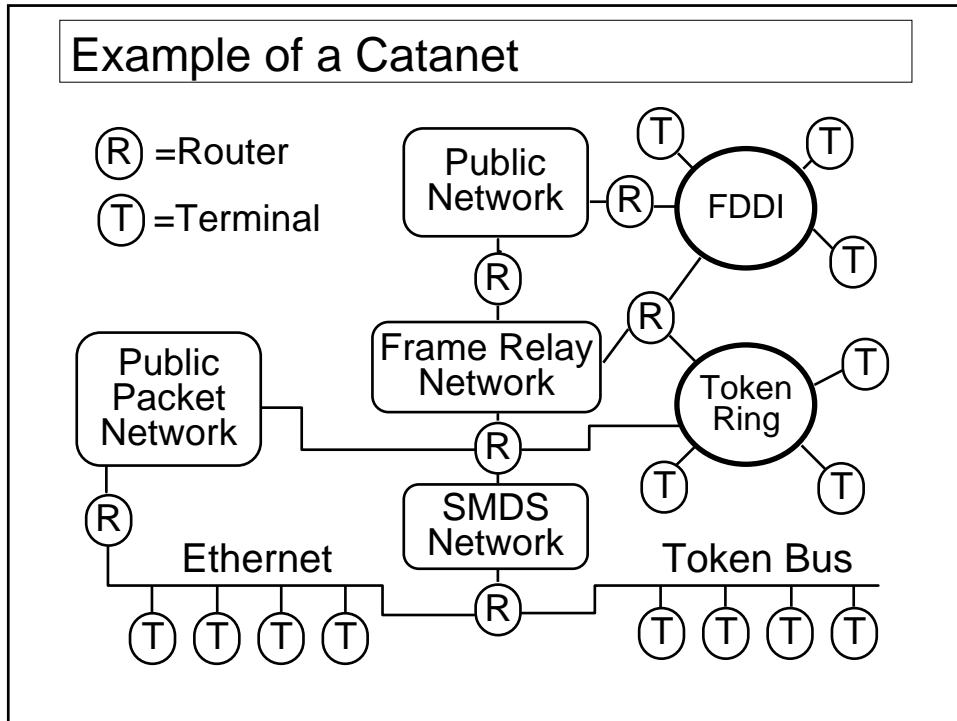

As with MAC bridges, routers are schizophrenic -- they are perfect members of all environments in which they participate.

## Wireless LANs

- We will return to the subject of wireless LANs (Wi-Fi & IEEE 802.11) after covering the TCP/IP Protocol Suite
- Wireless LANs are covered in Chapter 17 of the Textbook
- Using this approach will help in understanding of some of the features of wireless systems

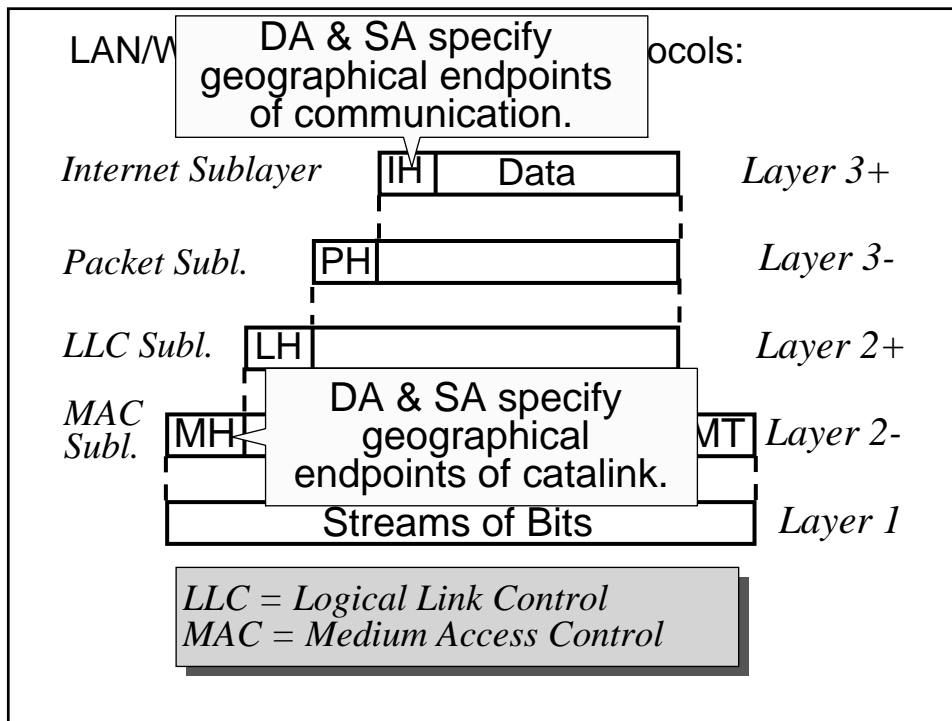

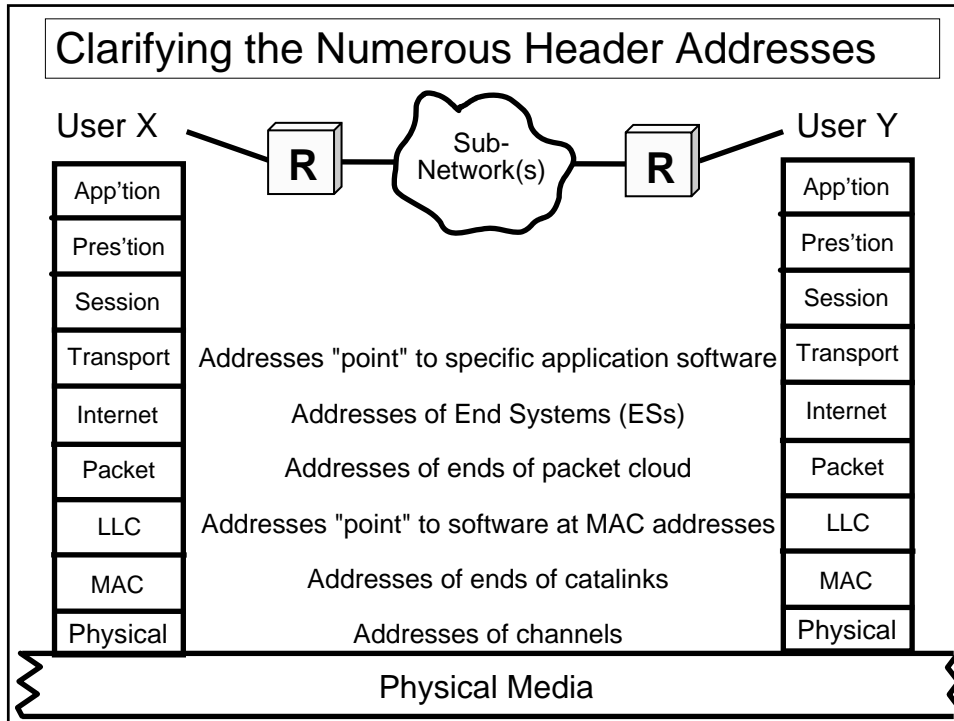

### TCP/IP – The Need – I

1. Improved media have made transmission errors less frequent, making acknowledgment and accountability at IS nodes in WANs less vital.
2. Practically all LANs operate with no acknowledgment or accountability. Received messages containing errors are simply discarded.
3. There needs to be a way to have end-to-end accountability without requiring it at individual nodes.

### The Need – II

4. Today's network is likely to become tomorrow's subnetwork. Network architectures must be flexible enough to allow convenient geographical growth.
5. Complex networks must provide for "firewall" protection against "hack attack" and for trouble isolation.
6. Robust networks must provide alternate routing for fault and congestion avoidance.

### The Answer

- During the 1970s, the U.S. DOD realized the need to create catanets for tying together its myriad networks.
- To fulfill this requirement, a series of Military Standards known as the TCP/IP Protocol Suite, Version 1, was developed.
- Vendors wanting DOD's business were required to conform, so TCP/IP became an instant success.
- Today's Version 4 offers much more.

## TCP/IP and its relationship to OSI

- Recall: TCP/IP pre-dates OSI.
- MS-1778, the Transmission Control Protocol (TCP) roughly equates to OSI Layer 4.
- MS-1777, the Internet Protocol (IP), roughly equates to Layer 3+.
- Other MSs are upper-layer processes, including file transfer (FTP), E-mail (SMTP), and a scroll-mode virtual terminal (TELNET).

## Significance of TCP/IP – I

- Can handle subnetworks that are connection-oriented or connectionless.
- Heterogeneous mixtures of subnetworks can be linked together.
- Later versions offer more robustness, but not all TCP/IP routers support all services and options.
- Unfortunately, TCP and IP cannot be separated. They are not modular.

